

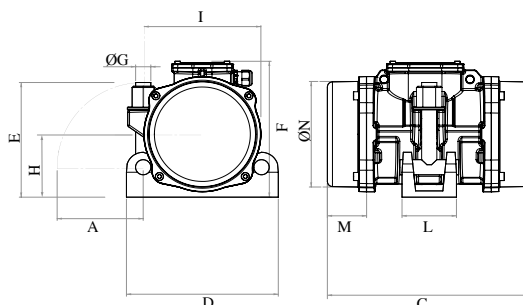

# MVE 2000/6N-HC-50A0 (CN40200050A0BA0000)

3 PH - 2 poles - 6000 RPM - 220-240/400-460 V - 200 Hz

Working moment [Kg*cm]	Unbalance [Kg*cm]	Centrifugal force [Kg]	Nominal voltage [V]	Input power [kW]	Current [A]	Power factor	Ia/In
9,48	4,74	1.907	220-240/400-460	1,6	Δ 4,38 Y 2,53	0,77	



\*Technical drawings are illustrative purposes only, please refer to 2D/3D drawings available on "FINDER" app. Contact us for more information.

## OVERALL DIMENSIONS (mm)

Weight [Kg]	G	Holes number	A	C	D	E	F	H	I	L	M	N
28,6	25	1	136	321	240	184	218	102	185	86	62	170

## TECHNICAL FEATURES

Type of grease	Greased for life	Screw	Washer	Clamping torque (Nm)	Cable type	Cable gland
KLUBER ISOFLEX NB52	Yes	M24	25 x 44 mm	360	4G2.5 80°C	M25 120°C

## BEARINGS LIFE HOURS

Bearing model	Type	100% C.F	80% C.F	50% C.F
NJ 306		/	/	/

## CERTIFICATION

Atex II 3D Ex tc IIIc Tx IP66 [Tx Size 10-30:100°C - Tx Size 40-91:135°C] T.Amb -20/+40°C				
---	--	--	--	--

REV.6-03/06/2021

Dimension with coarse degree of accuracy related to UNI 22768/1 Rights reserved to modify technical specifications.



PO Box 111, Charlestown NSW 2290  
Unit 7/8 Kilcoy Drive, Tomago NSW 2322  
P: 1300 026 011 | E: graham@bulkquip.com.au  
www.bulkquip.com.au